

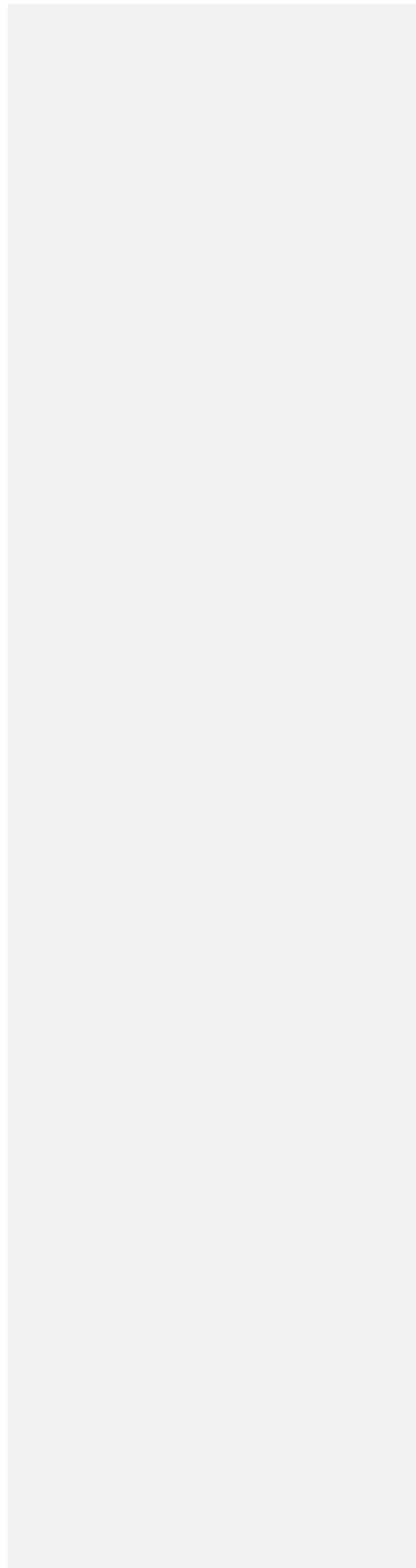

# **Elo Touch Solutions IntelliTouch® Integration Guide**

SW602314 Rev A

E204701



**Copyright © 2015 Elo Touch Solutions, Inc. All Rights Reserved.**

No part of this publication may be reproduced, transmitted, transcribed, stored in a retrieval system, or translated into any language or computer language, in any form or by any means, including, but not limited to, electronic, magnetic, optical, chemical, manual, or otherwise without prior written permission of Elo Touch Solutions, Inc.

#### **Disclaimer**

The information in this document is subject to change without notice. Elo Touch Solutions, Inc. and its Affiliates (collectively "Elo") makes no representations or warranties with respect to the contents herein, and specifically disclaims any implied warranties of merchantability or fitness for a particular purpose. Elo reserves the right to revise this publication and to make changes from time to time in the content hereof without obligation of Elo to notify any person of such revisions or changes.

#### **Trademark Acknowledgments**

Elo, the Elo logo, Elo Touch, Elo Touch Solutions, Elo TouchSystems, IntelliTouch, and IntelliTouch Zero Bezel are trademarks of Elo Touch Solutions, Inc. and its affiliates in the United States, other countries, or both.

All other product and company names used herein may be trademarks of their registered owners.

# Table of Contents

<b>Chapter 1: Introduction</b> .....	4
<b>Chapter 2: Definition of Terms</b> .....	7
<b>Chapter 3: Touch Screen Integration Design Guide</b> .....	9
<b>Chapter 4: Touchscreen Customization Options</b> .....	15
<b>Chapter 5: Controller Integration Design Guide</b> .....	17

# Chapter 1: Introduction

## About This Manual

This Elo Touch Solutions, Inc. (“Elo”) manual guides the user through the successful implementation of an IntelliTouch® IT touchscreen into a monitor, touchcomputer, or other electronic device. The intention of the manual is to make integration straightforward while optimizing IntelliTouch IT functionality. The intended audience of this manual includes: mechanical design engineers, system engineers, electrical engineers, manufacturing engineers, and product/project managers. Though some of the concepts here may be applicable to other Elo touchscreens, this manual is specific to IntelliTouch IT Surface Acoustic Wave (SAW) technology.

Chapter 1 explains the technology behind an IntelliTouch IT touchscreen. Chapter 2 defines important terms associated with IntelliTouch IT integration. Chapter 3 describes how to design and integrate IntelliTouch IT touchscreens into monitor systems with proper mounting, sealing, and spacing. Chapter 3 also provides information on appropriate materials and installation techniques. In Chapter 4, a variety of customization options are presented. Chapter 5 covers the controllers that can be used with the screens. After reading through this manual, if you still have questions or need help getting your system up and running, please contact an Elo Sales Representative.

## IntelliTouch IT Touchscreen

The IntelliTouch IT features include:

- Pure glass construction allows IntelliTouch IT to offer excellent image clarity (up to 92% light transmission) and durability (Mohs hardness of 6.5)
- Extremely fast and high resolution touchscreen
- Activated by soft stylus, finger, and gloved hand

Figure 1-1 illustrates how IntelliTouch IT technology works. Each axis of the touchscreen has a transmitting and receiving piezoelectric transducer, and arrays of reflector stripes.

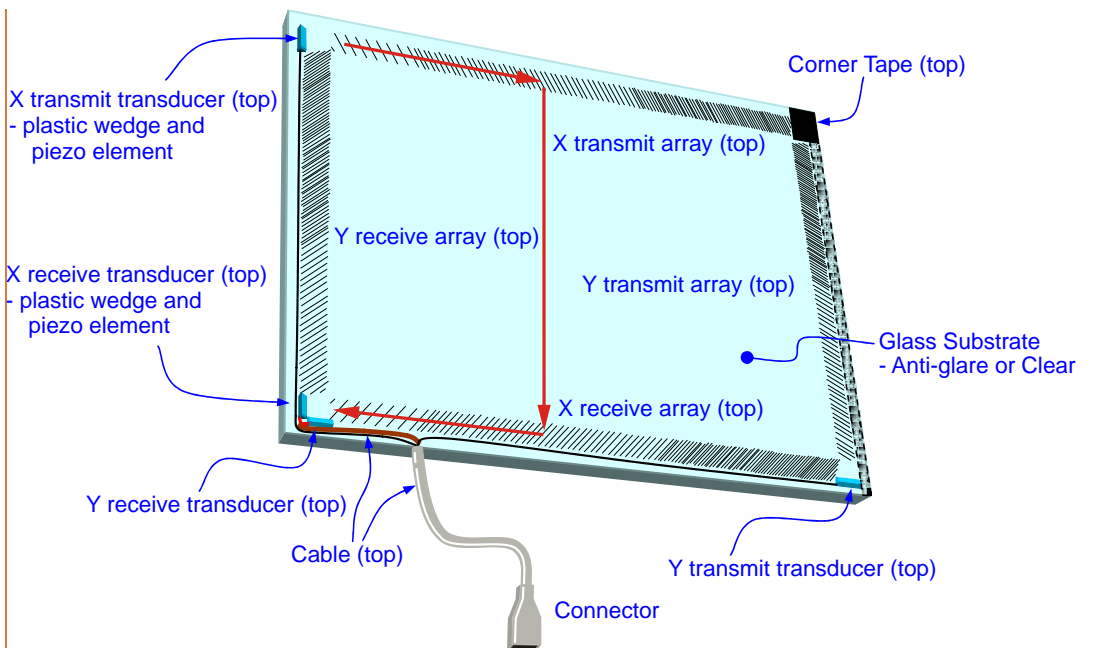

**Comment [LF1]:** For safety?  
Anti-glare

Figure 1-1. Front of the IntelliTouch IT Touchscreen

Surface waves are generated by the transmitting transducers mounted in the corners of the touchscreen. The touchscreen controller sends an excitation burst to the transmitting transducer which generates surface waves, represented by the solid arrows over the arrays in Figure 1-1. The array of reflector stripes located on the top edge of the glass reflects these waves towards the active area of the glass. After traversing the touch area, the waves reach reflector array reflector stripes which gather the reflected waves and direct them to the receiving transducer which reconverts the surface waves into an electrical signal.

When a finger or stylus touches the IntelliTouch IT screen, a portion of this signal is blocked thus allowing the touchscreen controller to determine the touch location. Once the X, Y, and Z coordinates have been determined, the controller transmits the data to the computer.

The controller maintains a no-touch reference signal. This reference signal is continuously updated to adapt to electronic drift and effects of contamination such as dirt and scratches. The live signal is compared to the reference signal to detect touches.

## The IntelliTouch IT Controllers

IntelliTouch IT controllers are available with a USB or serial RS-232 interface.

Spatial resolution of the IntelliTouch IT system is defined by the controller resolution of 4096 x 4096 and physical screen dimensions. Controller documentation is available from an Elo Sales Representative. For IntelliTouch IT single-touch applications, look for the Elo 2701 controller. Multi-touch applications will use an Elo 2515, 2520, 2521 controller or equivalent HID controller, as shown in Chapter 4.

## Driver Software

Drivers are generally written to match the operating system of the computer. Elo provides driver programs for common operating systems, including: Microsoft Windows 8/7/Vista/XP, Linux®, Android™, and Mac®. Additional drivers may be available for other operating systems. All drivers are available on the Elo website at

<http://www.elotouch.com/Support/Downloads/dnld.asp>.

Help with driver installation and calibration can be found in the Driver Read-Me document that comes with the Elo driver software.

## Chapter 2: Definition of Terms

- **ACTIVE AREA (AA):** The area of a screen which is responsive to touch.
- **ANTI-GLARE (AG) FINISH:** A treatment that roughens the surface of glass. The AG coatings scatter specular reflections into a wide viewing cone to diffuse glare and reflection.
- **ANTI-REFLECTIVE (AR) COATING:** A multi-layer coating on the surface of the glass that reduces the intensity of the light that is reflected. Elo does not recommended addition of AR coatings for touch screens since they are expensive, increase coefficient of friction and show finger prints.
- **ARRAYS:** Acoustically reflecting line segments that act as beam splitters and deflect surface acoustic waves into or out of the active area. The location of these arrays can be seen in Figure 2-1.
- **BEVEL:** Refers to the process of cutting the edges of a piece of glass to a specific angle and size in order to produce an elegant, framed look. This process leaves the glass thinner around the edges of the piece, while the large middle portion remains thicker. This allows a place to mount transducers so they do not protrude as far above the front surface of the glass.
- **BEZEL:** Depending on the industrial design, the part of the enclosure that may cover the Border Area.
- **BORDER AREA:** The area surrounding the Viewable Area.
- **CHASSIS:** The supporting frame of a system.
- **CHEMICAL STRENGTHENING:** The chemical strengthening process toughens soda lime and other glass substrates through a sodium and potassium ion-exchange process in a salt bath.
- **CONTROLLER:** The electronic device that converts analog touch signals into digital touch information that is communicated to a Host Computer.
- **DISPLAY:** Typically, a Liquid Crystal Display. Also referred to as a panel.
- **FLAT PROFILE:** An Elo patented design that uses grating transducers to minimize that height of components on the front surface of the touch screen.
- **HID:** Human Interface Device. Standardized protocol that eliminates the need for a specialized driver.
- **HOST COMPUTER:** The computer system in communication with the controller and in communication with the display, often running an operating system and application programs that make use of touch information.
- **HOUSING OR ENCLOSURE OR CASE:** The molded plastic cabinet of the system. The case normally covers the top, sides, back, and bottom of the system.
- **INTELLITOUCH ZERO BEZEL SCREENS:** An Elo patented design in which the transducers and reflector arrays are placed on the back side of the glass. The Surface Acoustic Wave travels around the edge of the glass to the front. These screens are covered in detail in the IntelliTouch ZB Integration Guide.
- **IP CODE:** International Protection Marking, per IEC standard 60529, classifies and rates the degree of protection provided against intrusion of foreign objects, dust, and water by mechanical casings and electrical enclosures. It is published by the International Electrotechnical

Commission (IEC). IntelliTouch IT screens can be sealed with foam to an IP51 rating where the first digit refers to foreign objects and dust and the second digit refers to protection against dust.

- **LCD:** Liquid Crystal Display is a flat panel display that uses liquid crystals to modulate the light.
- **MOUNTING TAPE:** Double-sided tape used to attach the touchscreen to a surface. The mounting is usually on the back.
- **PARALLAX:** The difference in the apparent location of an object versus the exact location of an object when viewed at varying distances and angles. This is the difference between the perceived touch location and the actual touch location due to touchscreen thickness and the distance between touchscreen and LCD.
- **PIEZO:** Short hand for piezoelectric element. In Elo IntelliTouch IT screen the piezo is generally a thin rectangular slab of piezoelectric ceramic with conductive electrodes on either side. Its function is to convert electrical signals to ultrasonic vibrations (transmit mode) or vibrations into signals (receive mode). The piezo is a key component of a SAW transducer assembly such as a wedge transducer.
- **SEALING FOAM:** Foam applied around the active area of the touchscreen to keep spills or dust build-up from affecting the reflector arrays. The foam must be adhered to the bezel, not to the touchscreen. The allowable sealing area is shown in Figure 2-1.
- **SYSTEM:** Touch monitor, computer, or other electronic device being integrated with the touch screen.
- **TEMPERED:** A method to thermally strengthen glass. Full tempering require a 3mm or thicker glass substrate imparting a higher thermal strength and a safety dicing break pattern (when broken dices into many small pieces for safety). Heat strengthened glass is generally twice as strong as standard annealed glass, while full tempered glass is typically four to six time stronger than annealed glass. Elo does not recommended using tempered glass for SAW touchscreens.
- **TRANSDUCER:** A touchscreen subassembly that converts electrical energy and surface acoustic wave energy. The transducer may be a “transmit” or a “receive” transducer depending on the direction of conversion.
- **VHB:** 3M® Very High Bonding pressure-sensitive adhesive (or equivalent) is often used to mount the touch screen.
- **VIEWABLE AREA:** The area of a screen where images can be seen.

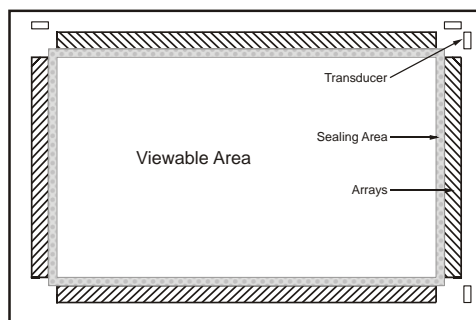

Figure 2-1. Important regions of the IntelliTouch IT screen



## Chapter 3: Touchscreen Integration Design Guide

This section of the manual is intended to help design your monitor, touchcomputer, or other electronic device with an Elo Touch Solutions touchscreen. Details are given on mounting and sealing the touchscreen, and routing cables.

### Reference Integration Design

Several options exist for mounting and sealing the screen. The cross-section of a reference integration design for an IntelliTouch IT touchscreen is illustrated in Figure 3-1. It is the simplest method of integrating a standard off-the-shelf or custom IntelliTouch IT screen. Important elements of the integration are described in the sections that follow.

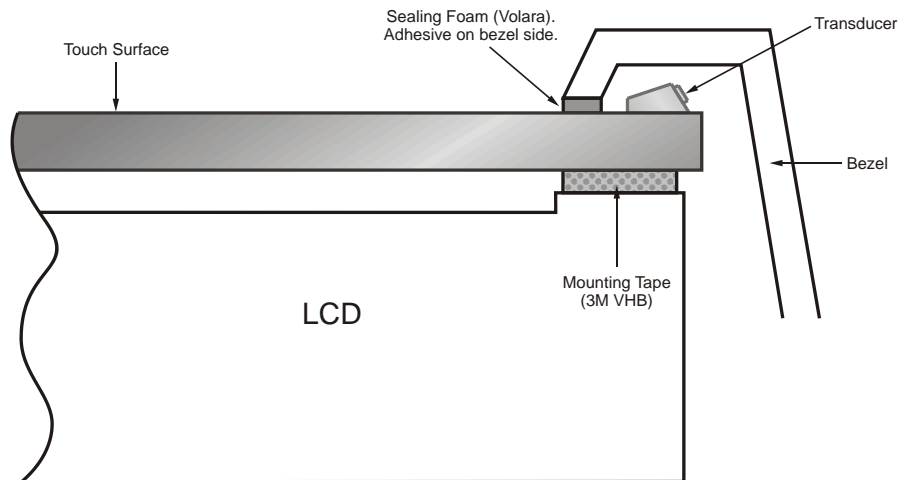

Figure 3-1. Reference Integration Design (not to scale)

### Design Considerations

The following design considerations are based on the integrated design in Figure 3-1.

#### Mounting

In the reference design shown in Figure 3-1, the IntelliTouch IT screen is mounted directly onto the metal of the LCD. This design minimizes the space between the touch screen and the LCD, thus minimizing parallax. It also creates a seal between the touchscreen and LCD panel to keep dust and moisture out.

An alternative solution is to mount the touchscreen onto a plastic sub-bezel. Sub-bezels make the units easier to replace in the field, but add to the thickness of the unit and make good adhesion harder to achieve. VHB does not bond readily to plastic, so if you are interested in mounting the touchscreen to a sub-bezel, a primer will be needed to get proper adhesion. Elo suggests a 3M primer with curing step.

Use double-sided tape on all four sides to attach to display

- 2 mm thick for flats > 15"
- 1 mm thick for flats <= 15"
- Acts as dust seal as well as an adhesive
- Or substitute foam tape on two sides

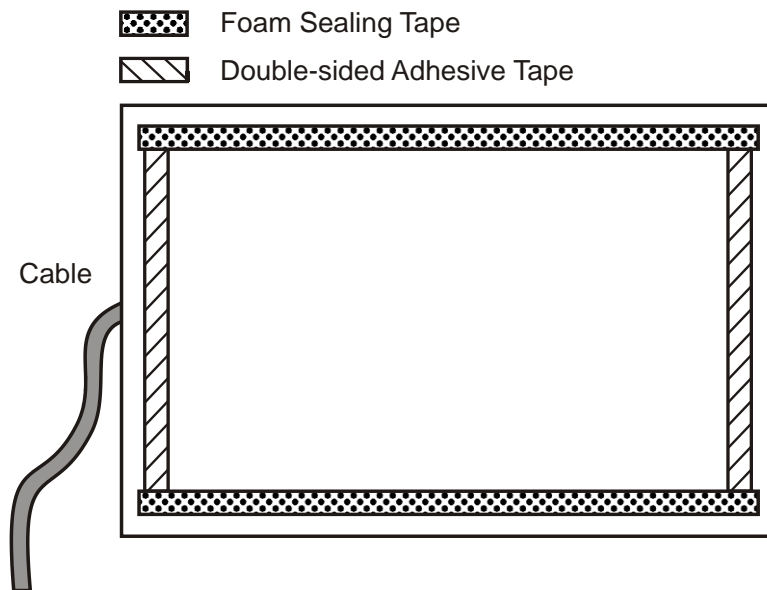

Figure 3-2. Mounting Tape

## Sealing

A seal is recommended between the touchscreen and the bezel to keep dust and spills from affecting array functionality. In the reference design, a seal is created with low density foam. The foam should be adhesive on one side only; the foam must be adhered to the bezel, never to the touchscreen. Elo Touch Solutions recommends low density closed cell foam like Volara® 2A, 2E, 4A, and 4E manufactured by Voltek®. This foam absorbs a minimum of the SAW signal. The screen can be sealed to IP51 rating with this foam.

Alternatively, a seal can be achieved with certain rubber wiper blades. The rubber material absorbs

more acoustic signal than low-density foam, but is an acceptable solution due to its narrow contact area. Wiper blade sealing allows for narrower borders, but requires a careful design that incorporates a wiper mounting groove.

## Simple Steps for Sealing

1. The seal should contact the touchscreen inside of the reflector arrays as shown in figure 3-3.

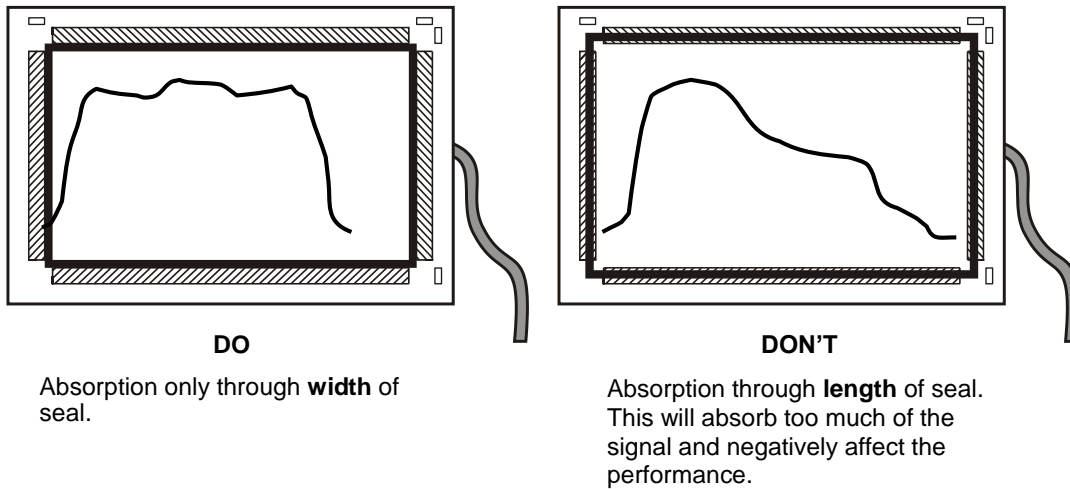

Figure 3-3 Sealing Location

2. Place the seal flush with the bezel. See Figure 3-4.

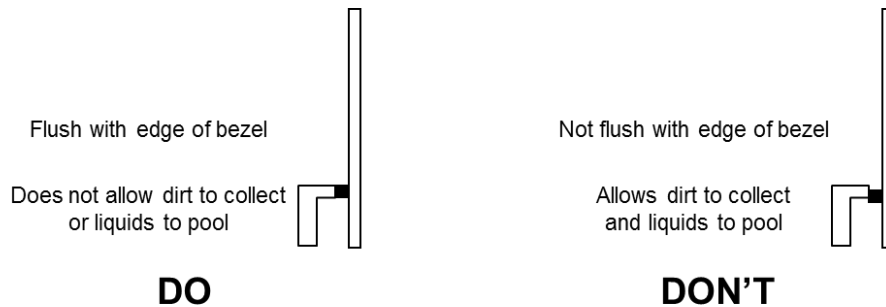

Figure 3-4 Flush Seal

3. A hard stop can be used to control the maximum compression of the seal as shown in Figure 3-5.

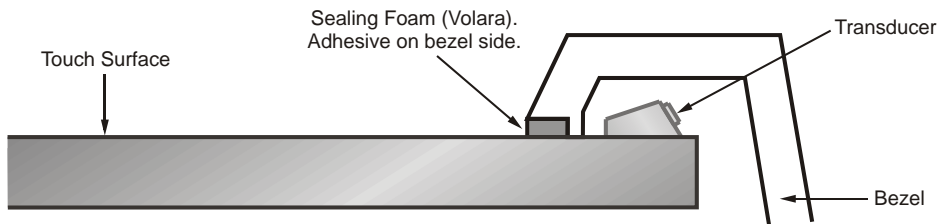

Figure 3-5. Integration with a hard stop

4. Compress the seal evenly all around the bezel.

## Glass

Standard IntelliTouch IT screens have a glass thickness of 2.7mm to 3.0mm.

## Touchscreen Reflector Arrays

It is important that no soft material or adhesive touch the arrays. No soft material or adhesive, except low density sealing foam or a wiper blade, should touch the area between the arrays and the active area of the touch screen. Contact with these materials will have a negative impact on performance. While immediate touch function may not appear to be impacted, long term acoustic signal performance may be at risk.

## Transducers

IntelliTouch IT touchscreens have transducers at the end of each array. There is some variation in transducer location on each screen. Elo recommends leaving a 1 mm clearance gap around each transducer to prevent damage by inadvertent contact. This clearance gap is highlighted in Figure 3-6. The transducers protrude about 3mm above the surface of the glass. The transducer area includes transducer and strain relief gel, shown in Figure 3-6 as the white rectangle. Figure 3-7 shows methods to insure that there is enough vertical clearance for the transducers.

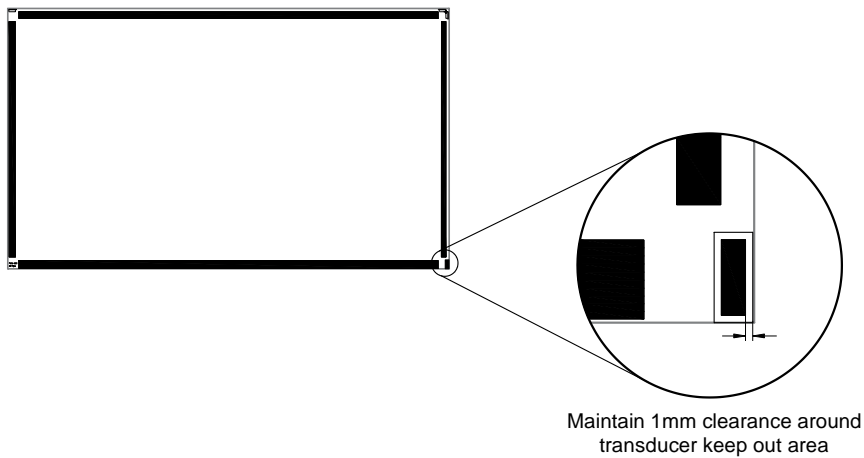

Figure 3-6. Clearance gap around transducers

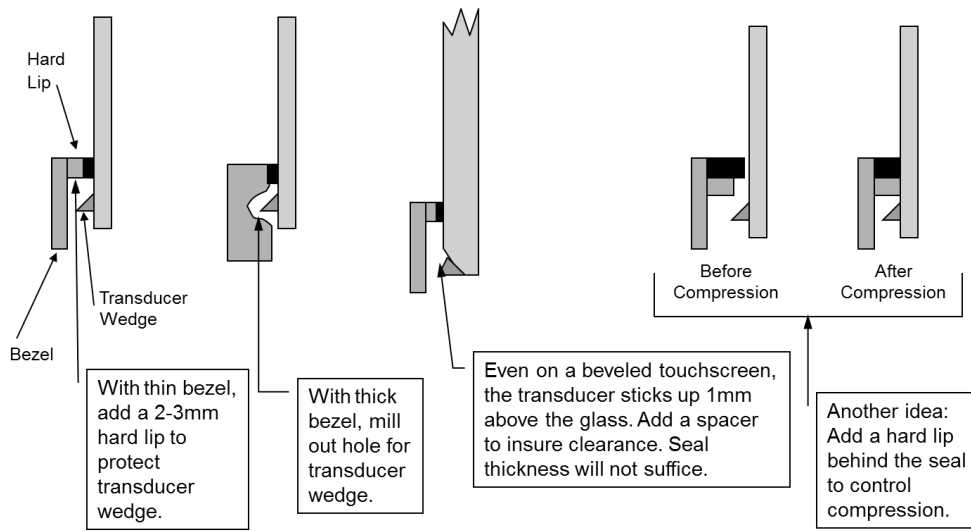

Figure 3-7. Vertical clearance for transducers

## Cable Routing

Cable routing is important for proper screen function and should be determined prior to integration. IntelliTouch IT touchscreens come with cables connected to transducers and routed into a single connector that interfaces with the controller. Care must be taken with their routing so that they are not pinched or cut. Cables should not be routed over or near sources of RF noise, heat, or sharp objects.

## Installation Notes

Cables can be strained and damaged during installation. Damaged cables are a common cause of functionality failures, so it is important to protect them. The cables should be routed away from the LCD panel inverter, lamps, and power module. The cables should never be crimped. The cable can be bent with a radius of 10 mm or greater. Most importantly, cables must not be used as handles for picking up the touchscreen.

Care must also be taken to protect the transducers during installation. Transducers are fragile and should not be bumped during installation. The transducers should have at least 1mm space between them and other items in the display. Appropriate spacing is shown in Figure 3-6.

Additional installation considerations are as follows:

- Before mounting the touchscreen, clean the face of the display and the back of the touchscreen within the viewable area with household glass cleaner applied first to a disposable wipe. Never apply cleaners directly to the touchscreen. Be sure to remove all fingerprints. A compressed air nozzle with clean, dry air may be used to remove the dust on the sensor and on the monitor. The space between the touchscreen and the display face must be clean and free of any foreign objects.
- Do not leave any substance along the surface wave path, as this will affect the function of the touchscreen.
- The reflector arrays are fired glass frit and should not be brought in contact with any acid or alkali.
- Do not remove the clear and/or black tape on the front or back of the touchscreen.
- A fixture to help align the touchscreen with the LCD is recommended.
- Sealing material dimensions recommended are 2-4 mm wide and 1-2 mm thick. For a foam seal, the foam should compress to a level that is between twenty and fifty percent of its initial height. Uniform compression around the touchscreen is ideal. A hard stop should be molded into your housing to control compression. See the example in Figure 3-5.

## FUNCTIONAL TESTING

The Microsoft Paint application can be used to confirm the functionality of the touchscreen after installation and after 3-point alignment. There are 2 tests that can be done.

### 1. Accuracy:

Touch the screen and confirm that the cursor follows the finger.

### 2. Bezel Activation:

Use a force gauge equipped with a spherical rubber head ~20mm in diameter (Figure 3.8) to add a minimum of 1.0kg pressure to the middle of the four sides of the bezel (4 test points) while drawing the below test pattern on the screen using one finger. The test pattern must cross the perpendicular line starting at the test point location as shown in Figure 3.9.

There should be no additional lines or touch points (other than the test pattern) are shown on the screen while the bezel pressure  $\leq 1.0\text{kg}$ .



Figure 3-8. Rubber test head example

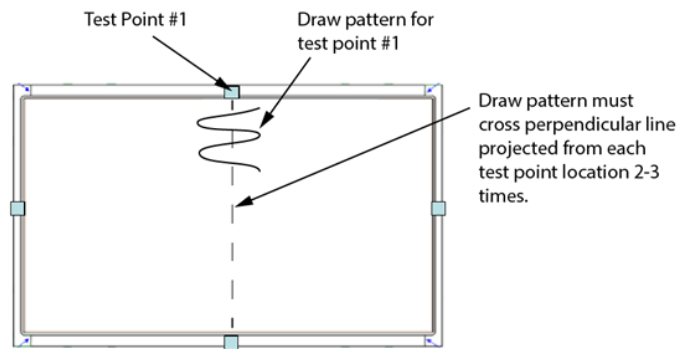

Figure 3-9. Bezel activation test pattern

# Chapter 4: Screen Customization Options

This section of the manual provides a list of customization options and constraints for the touchscreen.

## Beveled Touch Screens

Standard SAW touchscreens have wedge transducers that stand about 3mm off the print surface. Placing the transducers on bevels can reduce the amount the transducers protrude above the front surface to 1mm.



Figure 4-1 Beveled Screen

## Flat Profile Screens

Another way to reduce the amount the transducers protrude above the front surface is to use grating transducers. For these screens, piezos are adhered to the back side of the glass. The piezos create a pressure wave which travels through the glass. Grating printed on the front side converts the pressure wave into a Surface Acoustic Wave. The length of the reflector gratings, arrays and absorbing tape is 0.2mm above the front surface.



Figure 4-2 Flat Profile Screen

## IntelliTouch Zero Bezel Screens

The front surface can be made completely flat by using Elo Touch Solutions' patented Zero Bezel design. In this design the transducers and reflector arrays are placed on the back side of the glass. The Surface Acoustic Wave travels around the edge of the glass to the front. These screens are covered in detail in the IntelliTouch ZB Integration Guide.



Figure 4-3 ITZB Screen



## Chemical Strengthening

An ion exchange process can be used for soda lime and other types of glass to increase the strength of the glass used to make SAW touch screens.

## SecureTouch

The strength of the touchscreen can be further increased by increasing the thickness of the glass. Common thicknesses are 4, 5, 6 and 12mm. Edges can be beveled.

## Safety Glass

In this design, two or three layers of glass are used. The glass sheets are laminated using tough adhesive layers.

## Back Side Films

Films can be laminated to the back side of SAW touch screens. The film can be privacy, EMI shields or anti-shatter films.

## Cable Routing Alternatives

The screen can be designed so the cable exits from any side. The physical orientation of the transducers has no impact on the touch orientation. The touch orientation is manually configured in the 3-point calibration routine (provided with the driver) after the touchscreen has been integrated. The cables can be routed and adhered to the edges of the glass or to the front surface of the glass outside of the reflector arrays.

## Transducer Locations

Each IntelliTouch IT screen comes with transducers in three corners. The size of the transducers will vary according to the size of the touchscreen and the signal needed. These transducers must be aligned with the arrays; however, their locations can vary. Having transducers near the edge of the glass is useful in some instances because it places the transducers outside of the LCD frame. This is advantageous for decreasing the gap between the touchscreen and the LCD.

## Narrow Borders

Elo Touch Solutions design engineers make every effort to reduce border width. If needed, we can work with you to enable narrower borders.

## Coatings

Standard finishes for IntelliTouch IT screens are clear and anti-glare. The anti-glare is a treatment that roughens the surface of glass. The AG coatings scatter specular reflections into a wide viewing cone to diffuse glare and reflection.

## Release Liner

A removable protective release liner can be added to the front and/or the back of the screen upon request.

For more help with customizing your IntelliTouch IT touchscreens, contact your Elo Touch Solutions Sales Representative.

# Chapter 5: Controller Integration Design Guide

Elo will recommend the best controller for your application. The touchscreen has a cable to connect to the controller. The connection between the controller and computing system depends on the controller selected.

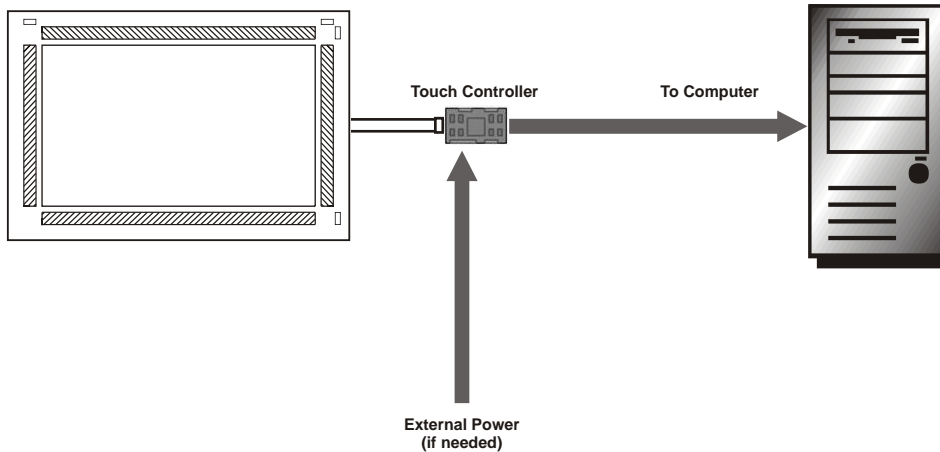

Figure 5-1. Basic System Overview

IntelliTouch IT controllers should be securely mounted to a metal bracket with good grounding and mechanical support. At least two of the plated mounting holes must be grounded. For the best EMI characteristics, ground all 4 holes. The controller should also be mounted at least 100 mm away from sources of electrical noise.

It is recommended that the power for the controller be linked with the display power to prevent accidental computer inputs in the event that the controller is powered, but the display is off.

For single touch applications, see specifications for the 2701 controller. For dual touch applications, see specifications for the 2515 controllers. For dual touch applications with HID compliance, see specifications for the 2520 and 2521 controllers. HID compliant devices eliminate the need for a driver.

## 2701 Controller (PN D68054-000)

The 2701 controller, CTR-270100-IT-RSU-00R, measures 53.3mm (2.1 inches) by 83.82mm (3.30 inches). Mounting holes located in each of the four corners have a diameter of 4.0mm (0.157 inches) and are centered 3.81mm (0.15 inches) from adjacent edges. The total height is 10.16mm (0.40 inches). Dimensional tolerances and further details are documented in the Elo Touch Solutions specification for the particular printed circuit card.

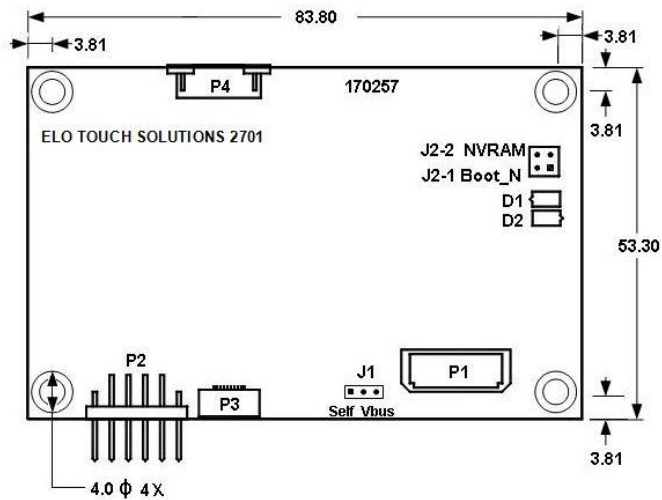

Figure 5-2. 2701 Dimensions: Top View (CTR-270100-IT-RSU-00R)

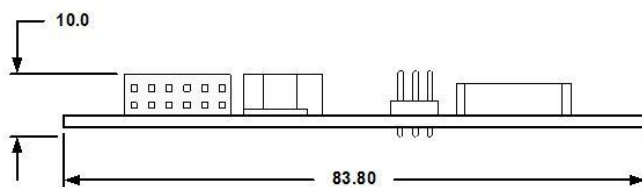

Figure 5-3. 2701 Dimensions: Side View (CTR-270100-IT-RSU-00R)

## 2515 Controllers (PN E545441, E096415)

CTR-251500-IT-USB-07-R measures 53.34mm (2.10 inches) by 83.82mm (3.30 inches) overall, while the small form factor version CTR-251500-IT-USB-05-R measures 40.00mm (1.57 inches) by 83.82mm (3.30 inches) overall.

Mounting holes located in each of the four corners have a diameter of 3.96mm (0.156 inches) and are centered 3.81mm (0.15 inches) from adjacent edges. Dimensional tolerances and further details are documented in the Elo Touch Solutions specification for the particular printed circuit card.

Total height of CTR-251500-IT-USB-07-R and CTR-251500-IT-USB-05-R is less than 15.62mm, broken down as follows: Components may extend a maximum of 11.5mm (0.45 inches) above the top of the p.c. board. Leads and bottom-side components may extend a maximum of 2.54mm (0.1 inch) below the bottom of the p.c. board. The PCB thickness is nominally 1.58mm (0.062 inches).

Type and location of connectors varies by model. See figures below for details.

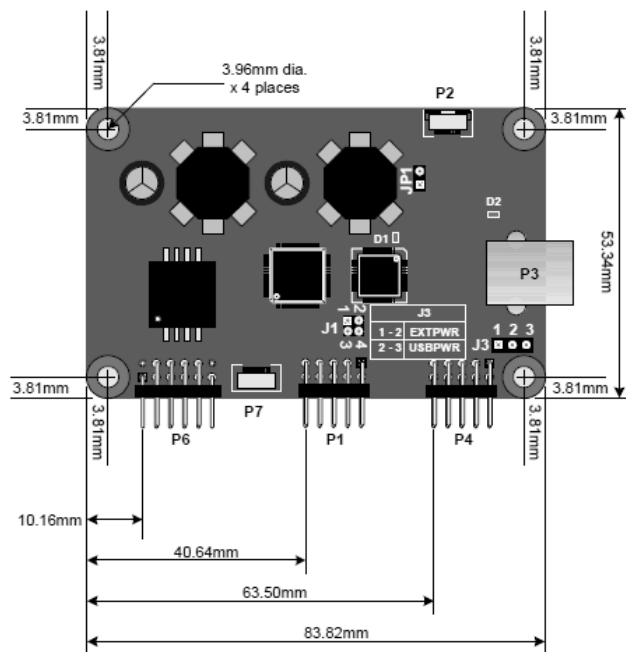

Figure 5-4. 2515 Dimensions (CTR-251500-IT-USB-07-R)

## 2520 Controller (PN E902552)

The Elo 2520 controller is a HID-compliant device that can be used for dual-touch applications.

The 2520 controller, CTR-252000-IT-USB-00-R, measures 40.00mm (1.57 inches) by 83.82mm (3.30 inches). Mounting holes located in each of the four corners have a diameter of 3.96mm (0.156 inches) and are centered 3.81mm (0.15 inches) from adjacent edges. Dimensional tolerances and further details are documented in Elo Touch Solutions specification for the particular printed circuit card.

Total height of CTR-252000-IT-USB-00-R is less than 13.8mm (0.54 inches). Components may extend a maximum of 9.5mm (0.45 inches) above the top of the p.c. board. Leads and bottom-side components may extend a maximum of 2.54mm (0.1 inch) below the bottom of the p.c. board.

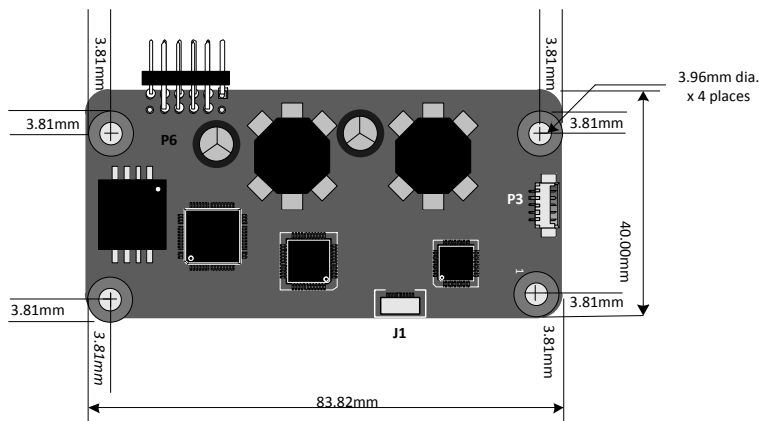

Figure 5-5. 2520 Dimensions (CTR-252000-IT-USB-00-R)

## 2521 Controller (PN E156921)

The Elo 2521 controller is a HID-compliant device that can be used for dual-touch applications. The main difference between the 2520 and the 2521 is form factor.

The 2521 controller, CTR-252100-IT-USB-00-R, measures 53.34mm (2.10 inches) by 83.82mm (3.30 inches). Mounting holes located in each of the four corners have a diameter of 3.96mm (0.156 inches) and are centered 3.81mm (0.15 inches) from adjacent edges. Dimensional tolerances and further details are documented in Elo Touch Solutions specification for the particular printed circuit card.

Total height of CTR-252100-IT-USB-00-R is less than 13.8mm (0.54 inches). Components may extend a maximum of 9.5mm (0.45 inches) above the top of the p.c. board. Leads and bottom-side components may extend a maximum of 2.54mm (0.1 inch) below the bottom of the p.c. board.

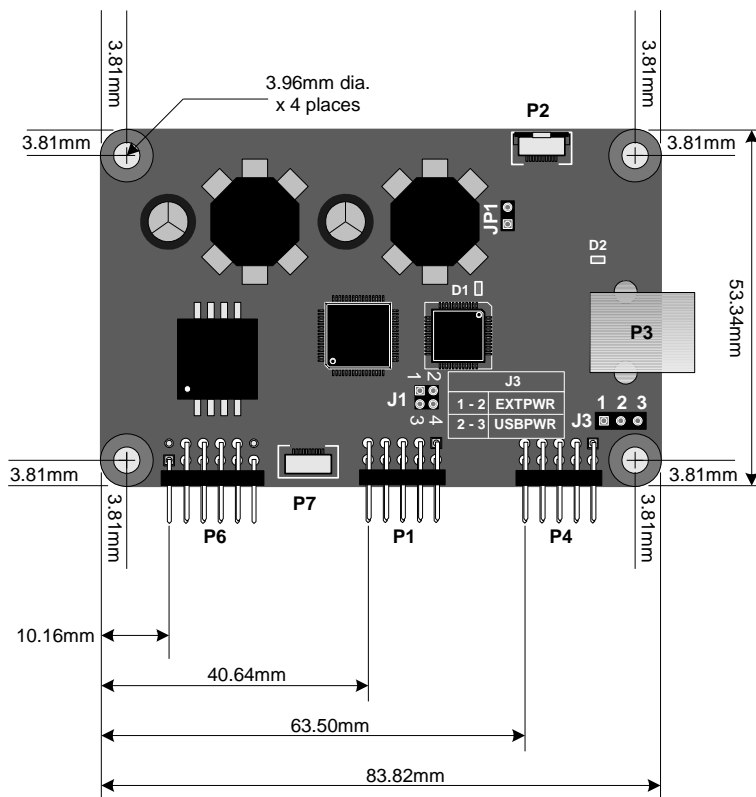

Figure 5-6. 2521 Dimensions (CTR-252100-IT-USB-00-R)

## Installing the Controller

- Verify power source and check specs for adequate power
  - Requirements: +5V  $\pm$  5% regulated, 0.100 amp
- Mount securely to metal bracket
  - Gives good ground and mechanical support
  - At least one plated mounting hole must be connected to ground, ground all 4 holes for best EMI characteristics
- Hot melt glue can be used to secure cable connectors to controller connectors.



Check out our website

**www.elotouch.com**

---

Get the latest...

- Product Information
- Specifications
- Upcoming events
- Press releases
- Software drivers

## Getting in Touch with Us

---

To find out more about the extensive range of Elo touch solutions, visit our website at [www.elotouch.com](http://www.elotouch.com), or simply call the office nearest you:

**North America**

Elo Touch Solutions  
1033 McCarthy Blvd  
Milpitas, CA 95035

Tel 800-ELO-TOUCH

Tel + 1 408 597 8000

Fax +1 408 597 8001

[customerservice@elotouch.com](mailto:customerservice@elotouch.com)

**Europe**

Tel +32 (0) 16 70 45 00

Fax +32 (0)16 70 45 49

[elosales@elotouch.com](mailto:elosales@elotouch.com)

**Asia-Pacific**

Tel +(81) 45-478-2161

Fax +81 (45) 478-2180

[tpsinfo@elotouch.com](mailto:tpsinfo@elotouch.com)

**Latin America**

Tel 786-923-0251

Fax 305-931-0124

[www.elotouch.com](http://www.elotouch.com)